

POTILA

OPERATING INSTRUCTIONS MAGNUM PLUS SEEDBED CULTIVATORS



**READ THIS MANUAL CAREFULLY BEFORE OPERATING
THE SEEDBED CULTIVATOR**

From serial number 12 1233 onwards

6/2015

Contents

- 1. INTRODUCTION..... 4
- 2. SAFETY GUIDELINES 7
- 3. SETTING-UP..... 11
- 4. HARROWING..... 23
- 5. MAINTENANCE   25
- 6. WARRANTY..... 35
- EC DECLARATION OF CONFORMITY 37

1. INTRODUCTION

Intended use

Technical specifications

1. INTRODUCTION

Intended use

POTILA MAGNUM PLUS seedbed cultivators are intended for preparing seedbed in either the spring or fall. The field can be ploughed or cultivated, and it can contain straw or other plant parts. The seedbed cultivator is used for loosening and crumbling the soil after primary tillage to produce a level seedbed and well-crumbled topsoil.

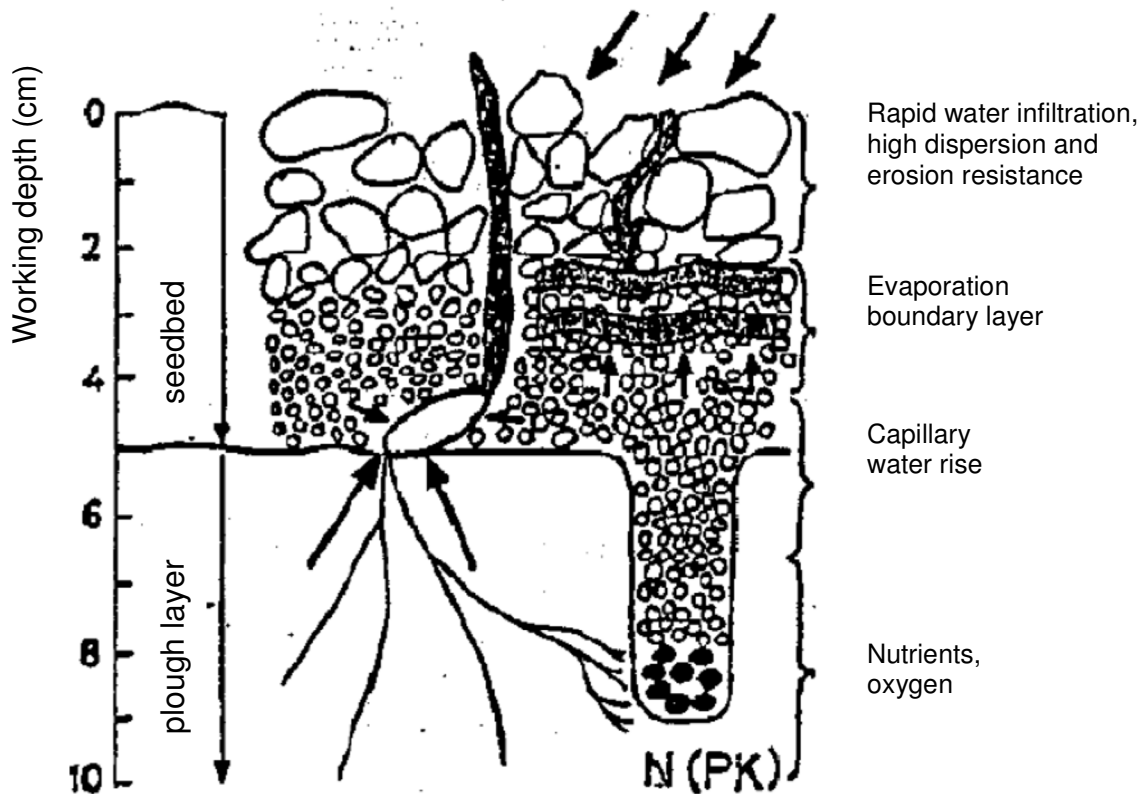

Figure 1. Recommended seedbed profile
(Heinonen 1971, page 85)

The seedbed cultivator is NOT intended for primary tillage of untilled soil!

The open frame structure of POTILA MAGNUM PLUS seedbed cultivators enables tine spacing that allows unrestricted, high-flow of soil. Level seedbed even on soft soil types is ensured by the tines that keep their working depth, accurate working depth control and large, high-capacity wheels.

POTILA MAGNUM PLUS seedbed cultivators are available with a wide range of optional equipment to ensure optimal granular structure and level soil surface.

Technical specifications

Type	MAGNUM PLUS	700	800	900	1000	1100
Number of sections		3	3	3	3	3
Working width, m		7,0	8,0	9,0	10,0	11,0
Number of tines		88	100	112	125	137
Number of tine axles		9	9	9	9	9
Draught requirement, kW		103	118	129	140	155
hp		140	160	175	190	210
Number of required hydraulic outlets single-/double-acting		-/3	-/3	-/3	-/3	-/3
Transport width, m		3,4	3,4	3,4	3,9	3,9
Working depth control						
M = mech. H = hydr.		H	H	H	H	H
Number of wheels		8	8	8	8	8
Wheel size		340	340	2340	340	340
Weight, incl. following harrow, kg		4000	4300	4650	5150	5350

FEATURES FOUND ON ALL TYPES:

- Tine type 1145, cross-section of material 11 x 45 mm.
- Tine spacing 8 cm.
- Wheels 340/55-16", diameter 780 mm, width 350 mm.
- Lights and reflectors.
- Hydraulically-controlled front crossboard as standard.

OPTIONAL EQUIPMENT:

- Following harrow with a tine diameter of 12 mm.
- Spiral rollers, diameter 27 cm.

Rear crossboard, controlled with front crossboard cylinders via linkage bars or individually by the tractor's hydraulic system, in which case 3 double-acting hydraulic outlets are required.

- The number of rear equipment is limited to a maximum of 2 pieces of equipment per seedbed cultivator.
- The standard front crossboard can be replaced with a 20-cm high full-wide front crossboard constructed of heavy bulb flat steel profile.
- All models can be equipped with a spare wheel.







2. SAFETY GUIDELINES



Warnings

Transport on roads

2. SAFETY GUIDELINES

Warnings

	<p>Pay special attention to all instructions and diagrams marked with this symbol.</p>
	<p>Read the manual carefully and make sure that you understand everything. All safety guidelines must be read carefully before hitching the seedbed cultivator to the tractor. Learn how to operate the cultivator carefully and in a correct manner.</p>
	<p>CRUSHING HAZARD! IMPACT HAZARD! Keep a safe distance of 10 meters always when the wing sections are raised or when the seedbed cultivator is operated.</p> <p>Never go under the cultivator unless it is supported.</p>
	<p>CRUSHING HAZARD! CUTTING HAZARD! Crushing and cutting hazard when raising or lowering the wing sections. Cutting hazard when adjusting rear equipment. Crushing and cutting hazard when hitching or unhitching the seedbed cultivator.</p>
	<p>FALLING HAZARD! Climbing on the seedbed cultivator frame is prohibited. Do not stay on the cultivator when it is being used or transported.</p>
	<p>HIGH HYDRAULIC PRESSURE HAZARD! High-pressure oil jet can penetrate skin and cause serious injury! High hydraulic pressure hazard when hitching or unhitching the seedbed cultivator.</p>
	<p>DANGER! Check the operation of locking devices before transporting the seedbed cultivator.</p>

	<p>Wear safety goggles when performing maintenance.</p>
	<p>Wear hearing protectors when driving.</p>

Instructions for the operator



- Never stay near the wing sections when they are in the raised position.
- Do not allow anyone to stay on the seedbed cultivator when it is being used or transported.
- Raising and lowering the wing sections may only be done when the cultivator is parked and **HITCHED TO THE TRACTOR**.
- Prevent the tractor from moving by applying the parking brake always before hitching the cultivator or performing maintenance!
- **Ensure that the wing sections are in the fully raised position and properly locked before driving off.**
- **Close the valve in the middle section wheel cylinder before driving on public roads.**
- **Close the valve in the hose for wing sections before driving on public roads.**
- When driving on public roads with the cultivator, exercise caution and obey all traffic rules.
- Before performing any maintenance on the cultivator, lower the wing sections and park the cultivator on a firm, level surface.
- Before performing any maintenance on the hydraulic system, position the cultivator on suitable jack stands on a firm surface.
- Always inspect the following cultivator components visually before driving on public roads:
 - The condition of the towing eye and its bolts.
 - The condition of the tyres and wheel bolts.
 - The condition of the draw bar and its bolts.
- Always use original spare parts for maintenance.
- Always observe the instructions and guidelines specified in this manual when adjusting, operating and servicing the cultivator.

Transport on roads

- Slowly raise the wing sections fully into the transport position. They are controlled with the same hydraulic valve as the front crossboard during harrowing.
- Ensure that the automatic locking bars lock into their holes and do not drive off before both wings are locked.



- Close valve A in the middle section wheel cylinder before transporting the cultivator on a public road.
- Close valve D in the control hose for wing sections before transporting the cultivator on a public road.
- Check that the cultivator is sufficiently clean before driving on a public road.
- Check the condition of the tyres and draw bar assembly.
- Check that the running lights are connected and that they work.
- Pay attention to the transport height.
- Drive carefully and obey all traffic rules.

Insufficient tyre pressure or high speed (over 40 km/h) may result in damage to the tyres!



REMEMBER TO KEEP YOUR HANDS AWAY FROM THE HYDRAULIC CONTROLS WHILE DRIVING ON THE ROAD!

3. SETTING-UP

Raising/lowering the draw bar

Hitching and hydraulics

Adjusting the seedbed cultivator

- Horizontal adjustment
- Middle section and wing section adjustment
- Depth adjustment
- Working depth indicator
- Use of the front crossboard
- Use of the rear equipment

Troubleshooting/FAQ

3. SETTING-UP



Always observe the tractor's safety guidelines when hitching or unhitching the seedbed cultivator. Crushing and cutting hazard when hitching or unhitching the seedbed cultivator. Never disconnect or connect hoses that are under pressure.

Raising/lowering the draw bar

The draw bar of the seedbed cultivator can be raised to reduce the space needed for storage (for example, in winter storage).

- Lower the support leg down.
- Lower the cultivator on its tines or jack stands.
- Unhitch the cultivator from the tractor tow hook but do not disconnect the hydraulic hoses from the tractor.
- Use the wheel hydraulics control to loosen the draw bar so that the draw bar top link can be detached.
- Disconnect the hydraulic hoses.
- Drive the tractor away from the cultivator.
- Attach the storage bar to the top link mounting point on the draw bar.
- Raise the draw bar using appropriate lifting devices and accessories. Exercise extreme caution when raising the draw bar!
- Attach the other end of the storage bar to the frame with the top link pin.
- Remove any lifting accessories.
- Push the support leg to the upper position.

Lower the draw bar in reverse order.

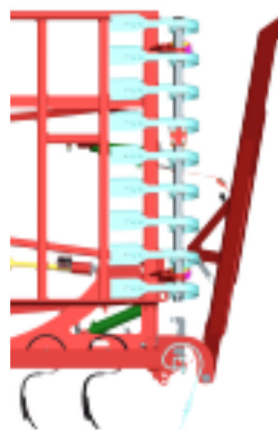
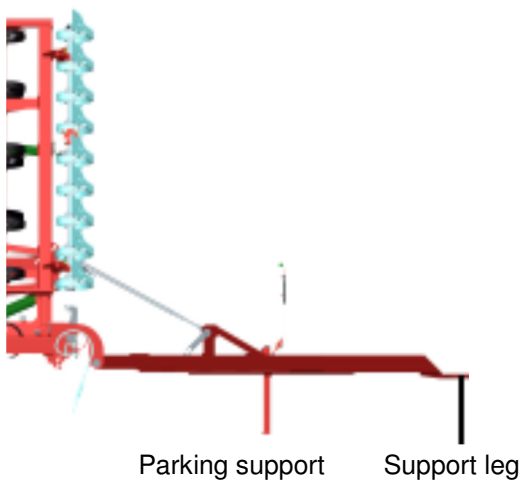

Hitching and hydraulics



Always observe the tractor's safety guidelines when hitching or unhitching the seedbed cultivator. Crushing and cutting hazard when hitching or unhitching the seedbed cultivator. Never disconnect or connect hoses that are under pressure.

- Hitch the cultivator to the tractor tow hook only.
- Ensure that the tractor tow hook locking is closed.
- Lift the support leg and lock it to the upper position.
- Connect the wheel transport hydraulic hoses (red) to a double-acting hydraulic outlet (diameter **19 mm**).
- Connect the depth control hydraulic hoses (blue) to a double-acting hydraulic outlet (diameter **19 mm**).
- Connect the front crossboard/wing section hoses (green) to a double-acting hydraulic outlet (diameter **14 mm**).

Wheel hydraulics

+ -

Depth control

+ -

Front crossboard/wing section control

+ -





- Open transport valves A and D. (The figure shows the valve in a closed position.)
- Lift the cultivator on its wheels.
- Drive the tractor with the hitched cultivator onto a firm, level surface.
- Lower the wing sections. **Ensure that the wing section extension areas are clear!** For this procedure, the cultivator must be in the transport position.
- The automatic section locking opens before the wing sections start to move.
- Balance the hydraulic circuits if necessary.

Balancing the hydraulic circuits

When using the cultivator for the first time after a long break, fully extend the piston rods of the cylinders connected in series using the wheel circuit hydraulics and keep the pressure on in the wheel circuit with the tractor's hydraulic control lever for 1–3 minutes.

The cylinders are fully extended when 250 mm of the front crossboard cylinder piston rods are exposed. For the wheel hydraulics, the corresponding dimensions are as follows: the middle cylinder 400 mm, wing section cylinders 290 mm.

This procedure will circulate hydraulic oil throughout the system, thus balancing motion differences and bleeding any air bubbles.

Remember to balance the cylinders connected in series if necessary!

Adjusting the seedbed cultivator



NOTE! Ensure that the wing section extension areas are clear. Remember the minimum safe distances!

Lower the wing sections as follows:

- If the cultivator is not in the transport position, lift the cultivator **all the way up** on its wheels. (The change valve will then direct the pressure to the wing section lift cylinders.)
- Ensure that the wing section extension areas are clear.
- Lower the wing sections carefully. The wing sections are lowered with the front crossboard control lever. The transport locking will open automatically when the wing sections begin to lower.
- Note that lowering the wing sections may create a vacuum in the hydraulic circuit.
- Using the tractor hydraulics, run the piston rods of the wing section lift cylinders **all the way out until they are fully extended**.

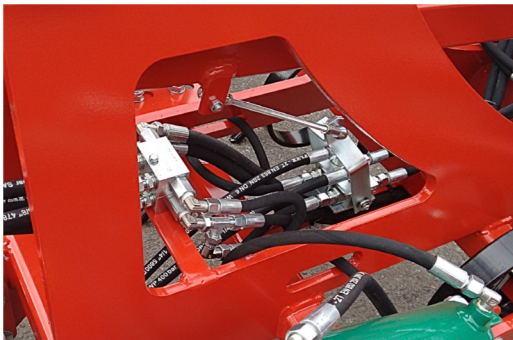

All models are equipped with change valve assemblies that control the front crossboard/wing section hydraulics. Their purpose is to distribute the pressure of the same hydraulic outlet to the front crossboard cylinders or wing section lift cylinders depending on the position of the cultivator (work or transport position).

Horizontal adjustment



The cultivator's horizontal straightness is adjusted by turning this top link. The front end of the frame lowers when the top link is retracted. Correspondingly, the front end rises when the top link is extended. This adjustment ensures even working depth of all tines.

Lower the cultivator on its tines so that the top link is loose. Open the top link lock plate. Adjust the top link to the correct length by turning it. Lock the lock plate.

Because the adjustment of this position depends on the height of the tractor tow hook, it must always be readjusted when hitching the cultivator to a different tractor.

MIDDLE SECTION AND WING SECTION ADJUSTMENT:

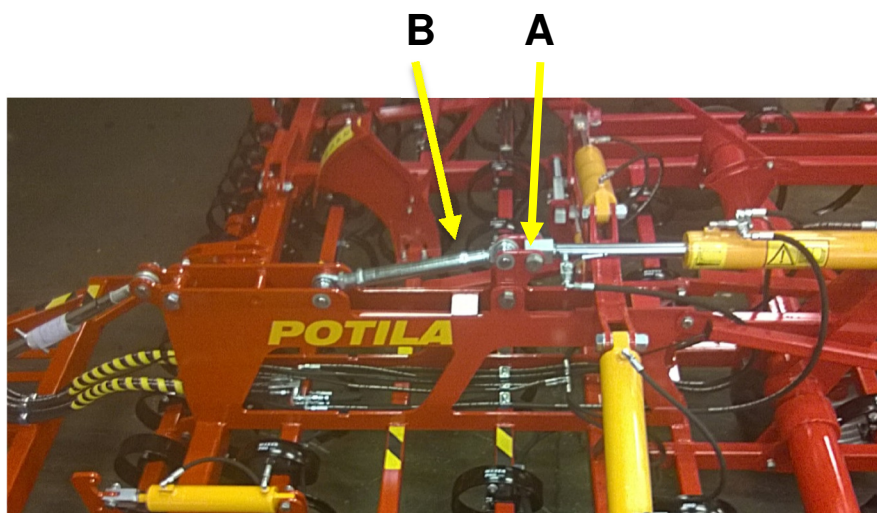

- The height of the middle section is aligned with the height of the wing sections by turning the piston rod of the middle cylinder (**B**).
- When the rod screw is extended, the middle section rises. Correspondingly, when the rod screw is retracted, the middle section lowers in relation to the wing sections.
- The end piece must be locked with the lock nut after adjustment.
- No more than 15 mm of thread may be exposed.
- Check this setting in the field before starting to harrow.



Lower the cultivator on its tines so that the mounting bolts of the cylinders have some play. Shut down the tractor! Pay special attention when you move between the frame of the cultivator to access the end piece to be adjusted. Never walk or stand on the frame!



C

The relative height of the wing sections can be adjusted by turning the cylinder piston rod. The end piece must be locked with the lock nut after adjustment. No more than 15 mm of thread may be exposed. Also check this setting in the field.



Lower the cultivator on its tines so that the mounting bolts of the cylinders have some play. Shut down the tractor! Pay special attention when you move between the frame of the cultivator to access the end piece to be adjusted. Never walk or stand on the frame!

WHEEL HYDRAULICS AND DEPTH CONTROL

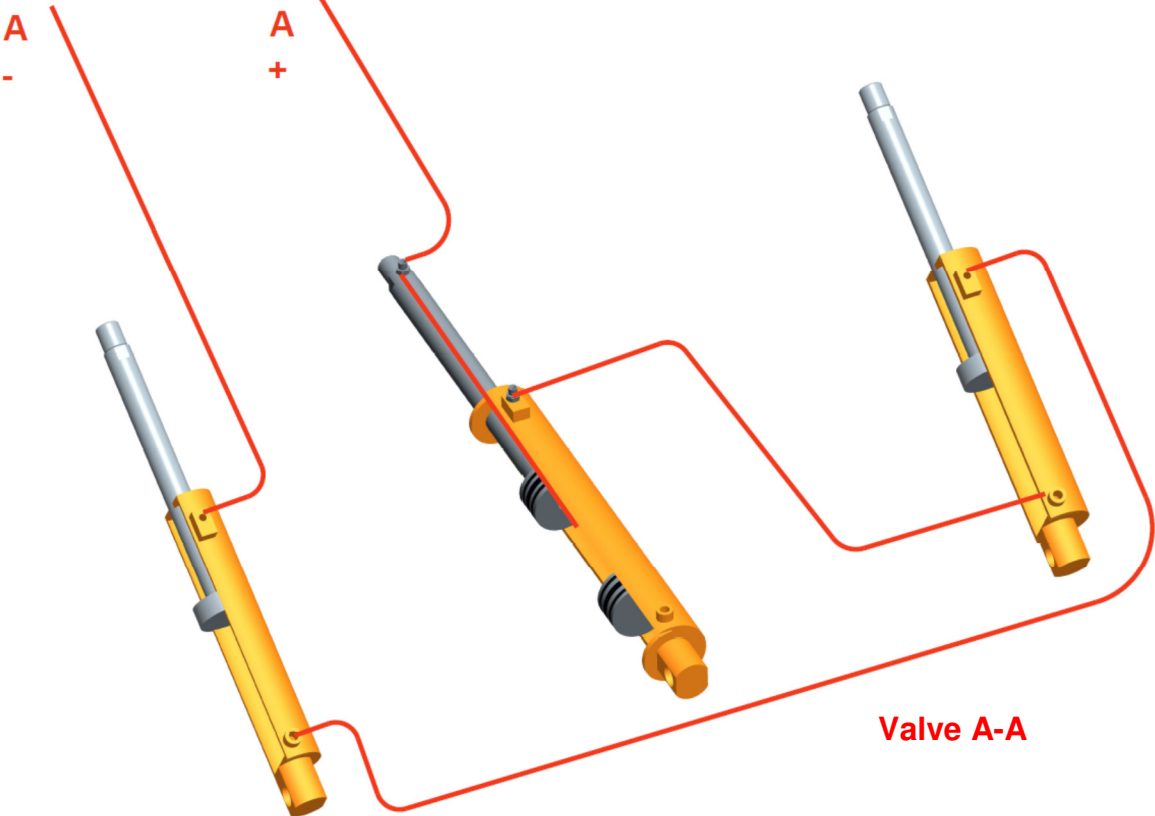

The hoses for the wheel hydraulics control circuit are marked with red.

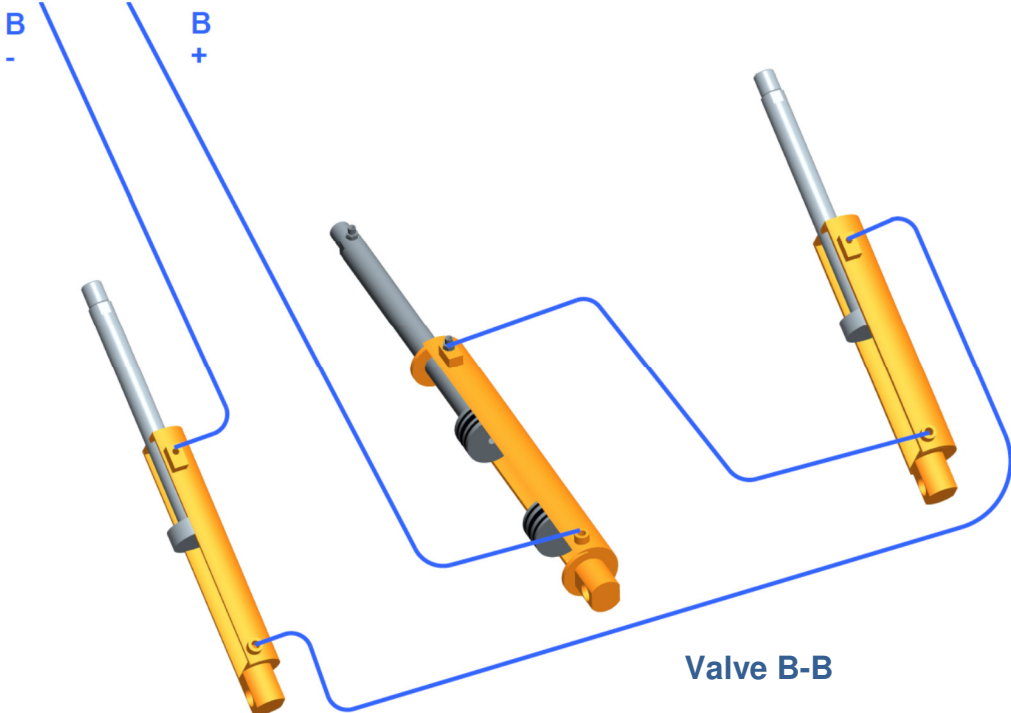

The hoses for the depth control circuit are marked with blue.

The working depth is controlled hydraulically:

- Check that the hoses are properly connected (+/–). Connect the hoses marked with the same colour to the same tractor valve.
- Fully retract the cylinder piston rods of the wheel hydraulics with the wheel circuit valve A–. The line is indicated in red in the figure.
- Select the control valve for the depth control circuit (the line indicated in blue in the figure) and fully retract the piston rods with valve B–. Then run the piston rods out with valve B+ until the desired working depth is reached. You can check the working depth from the working depth indicator.
- The working depth is now set. You do not need to use the depth control valve B-B unless you want to adjust the working depth. The cultivator is lifted and lowered with the wheel circuit valves A+ and A–. The line is indicated in red in the figure.

Hose markings: **Red = A-A = Wheel hydraulics**
 Blue = B-B = Depth control

The working depth must be measured from harrowed soil behind the cultivator and adjusted separately for each field and crop.

The working depth can be adjusted with valve B-B when driving.



The actual depth must always be checked by measuring harrowed soil behind the cultivator. Take measurements for each section.

Working depth indicator

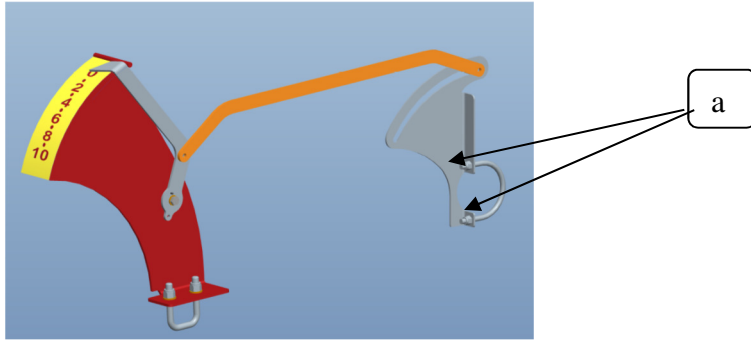

Magnum Plus seedbed cultivators are equipped with a working depth indicator which indicates the depth in centimetres. Adjust the indicator as described below.

The indicator is set to 0 at the factory, indicating the position in which the tines and wheels are at the same level.

When beginning harrowing, check the setting as follows:

- Measure the working depth behind the cultivator.
- Loosen the screws indicated with “a” in the figure.
- Turn the assembly until the indicator shows the measured value.
- Tighten the screws.
- Check the movement of the bar.

Use of the front crossboard

The front crossboard control only functions when the cultivator is in the working position, i.e. the tines are in the ground.

The front crossboard must be adjusted so that it levels the ploughed soil and transfers a row of soil equal to the height of the points in front of it. The position of the front crossboard can be controlled hydraulically while underway according to the soil type and need for levelling.



Use of the rear equipment



The tractor must be shut down and the parking brake must be applied when adjusting the rear equipment.

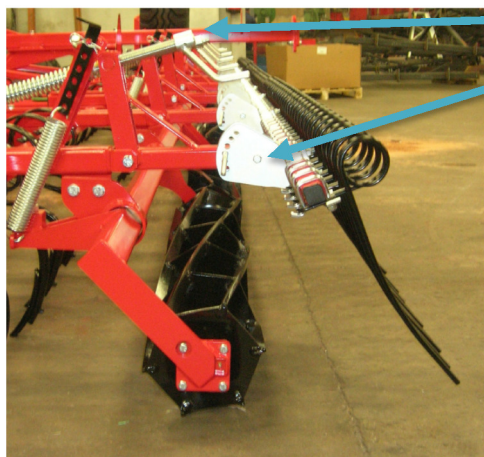

E
F

The position of the following harrow can be adjusted at points E and F. On clay soil, the following harrow most effectively turns fine soil to the right sowing depth if the tines are nearly perpendicular to the ground and the harrowing speed is 8–10 km/h.

Spring adjustment



When using a spiral roller for rear equipment, the roller is loaded by a draw spring. This spring should not be tightened excessively – the tension is correct if the soil surface is levelled and no traces of tines can be seen behind the roller. When the roller is used, the harrowing speed can be slightly higher than when using a rear crossboard, i.e. 8–12 km/h.

The spiral roller and following harrow can also be used simultaneously.

If necessary, the following harrow can be turned up and locked with a pin.

Suitable harrowing speed for this combination is 8–10 km/h.



Control with a linkage bar

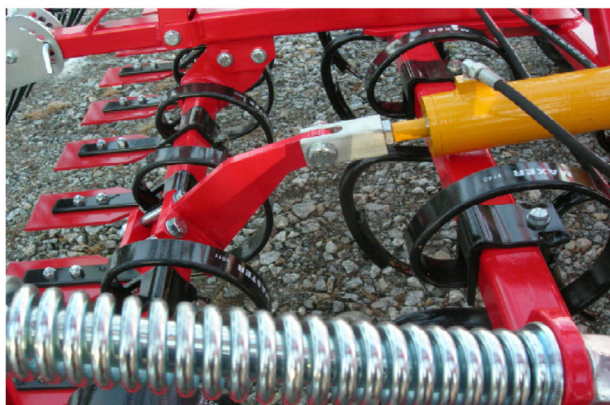

Control with a dedicated hydraulic circuit

The rear crossboard control options are as follows:

- Control with the front crossboard hydraulic circuit, in which case the movement is conveyed to the rear crossboard via a linkage bar. In this case, the relative position of the rear crossboard is adjusted with a crank connected to the linkage bar.
- Control with a dedicated hydraulic circuit, in which case the rear crossboard is controlled by separate cylinders connected in series. The hoses for this circuit are marked with yellow.



Troubleshooting/FAQ

Hydraulic control is not working:

- Check that there is no pressure in the hoses before connecting them to the tractor.
- Check that the hoses are connected to the tractor.
- Check that the hoses are connected to the correct connectors in pairs.
- Check that the wheel circuit shutoff valve is open.
- Check that the tractor's valve block is in a double-acting position.

The lifting and lowering functions of the front crossboard and wing sections work simultaneously:

- Check that the change valve control rod is connected and that it is not bent.
- Check the control rod adjustment.

The working depth is creeping:

- Balance the wheel cylinders by extending the piston rods fully and keeping the pressure on for 15 seconds for a couple of times with the wheel circuit hydraulics.
- Fully extend the piston rods of the wheel cylinders and disconnect the hoses from the tractor. If the cultivator lowers over 10 mm, there is an internal leak in the cylinders. If this is the case, please contact the manufacturer.

The front crossboard / rear crossboard is not moving in line:

- Balance the cylinders (see above). They must move in line. If not, check the end pieces of the cylinders and adjust.
- If the alignment is lost again, there is an internal leak in the cylinders. If this is the case, please contact the manufacturer.
- The front crossboard / rear crossboard is creeping during harrowing. Connect the hose pair to another coupling pair in the tractor. If the problem persists, please contact the manufacturer.

4. HARROWING

a. General

b. Driving lines

4. HARROWING

General

The S-tine cultivators are intended for producing a level seedbed. Normal working depth for cereals is 0–6 cm. Because the seedbed cultivator is adjusted at the factory on a level surface, more accurate adjustments must be made on the field (the soil type, sinking of the tractor wheels and other factors have an influence on the settings).

If the desired working depth exceeds 6 cm, each piece of equipment must be readjusted so that it works as intended. The cultivator must always be supported by its wheels, not by the front or rear equipment. Special attention must be paid to the spiral roller: its setting must be so loose that possible stones do not damage the roller.

Because the cultivator frame is long, it must be lifted in tight turns. During turning, tines move sideways or – in the worst case – backwards, subjecting the tines to high levels of stress.

Because the cultivator is heavy, special attention must be paid on any obstacles in the field or field edges. Drive around the obstacles or lift the cultivator and drive carefully over them.

If the soil surface is especially hard, adjust the cultivator for the first harrowing pass so that the front crossboard levels the soil and that the working depth is only 1–2 cm. Otherwise, hard lumps protruding from the uneven surface can cause a tine to kick back heavily that may cause damage to the tine.

Driving lines

When using tines that have high crumbling properties and are good in keeping their working depth, it is important to lift the cultivator during headland turns so that the tines touch the soil only lightly (on hard soil types). This is because the tines move sideways in tight turns, subjecting the tine clamps to high levels of stress. The tines at the edges of the wing sections of wide cultivators can also move backwards.

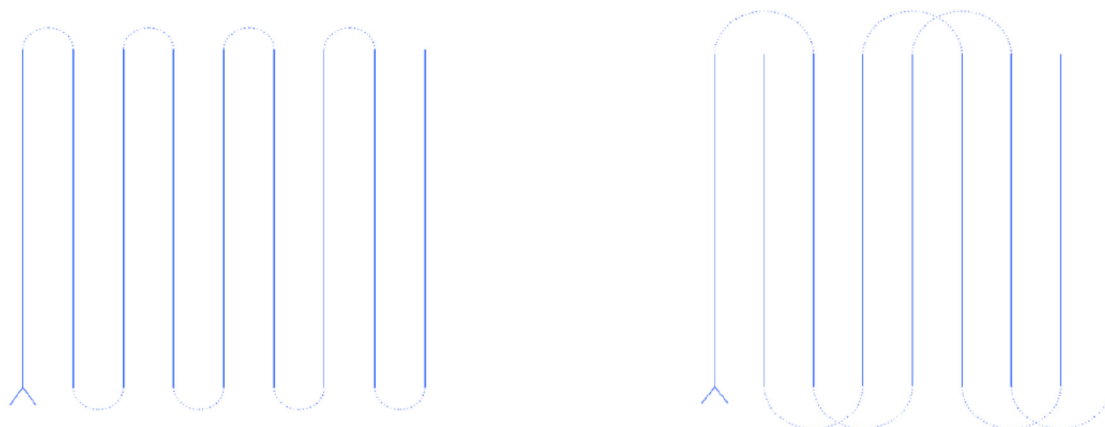

Driving line pattern in which the cultivator must be lifted in turns so that the tines are off the ground.

Driving line pattern in which the cultivator must be lifted to some extent in turns. The tines can touch the soil.

5. MAINTENANCE

- Key values
- Instructions
- Lubrication points
- Tine
- Bogie beam
- Wheel hub
- Hydraulics

5. MAINTENANCE



- Observe the safety guidelines specified in Section 2 when performing maintenance.
- Shut down the tractor before performing any maintenance procedures.
 - Support the cultivator with jack stands when performing maintenance.
 - Do not stay on the cultivator.

Key values

Tyre pressures:	200/60-14.5	6 bar
	250/65-14.5	4.4 bar
	340/55-16	4 bar
Tightening torque for the tines:		110 Nm
Tightening torque for the wheel bolts:		280 Nm
Tightening torque for the towing eye bolts:		210 Nm

Instructions

Check the following after the first day of operation:

- mounting of the tines
- tightening torque of the wheel bolts
- clearance of the wheel and bogie bearings
- tightening torque of the lock nuts of the cylinder end pieces.

Weekly maintenance:

- Check the mounting of the tines and wheels.
- Lubricate the hinges of the wing sections.
- Lubricate the slide bearings of the transport axle.
- Lubricate the joints of the wing section wheels.
- Check for oil leaks / signs of abrasion on hoses.
- Check the calibration of the working depth indicator.
- Check the condition of the draw bar assembly (towing eye, draw bar, bolts).

After the season:

- Clean the cultivator.
- Lubricate all nipples.
- Check the clearance of all bearings and adjust if necessary.
- Check the condition of consumable parts and replace/reverse if necessary.
- Check the tightening torque of the lock nuts of the cylinder end pieces.

Winter storage:

- If the cultivator is to be stored for a longer period of time, clean and lubricate it thoroughly. If a high-pressure washer is used for cleaning, do not aim the water jet directly to the cylinders, bearings and stickers.
- Never keep the nozzle of the high-pressure washer closer than 30 cm from the surface to be washed.
- Lubricate the cultivator after it is washed.
- When the cultivator is stored, the hydraulic cylinders must be positioned so that a minimum amount of chromed piston rod is exposed.
- Any exposed piston rod sections must be protected with petroleum jelly or suitable oil. If necessary, the draw bar assembly of the cultivator can be raised to reduce the space needed for storage. If the cultivator is to be stored for a longer period of time, it must be placed in a suitable shed or shelter to prevent the sun and other elements from damaging the rubber components and paint.
- For any queries regarding spare parts and accessories, please contact the cultivator dealer.
- Use only original spare parts.

Lubrication points

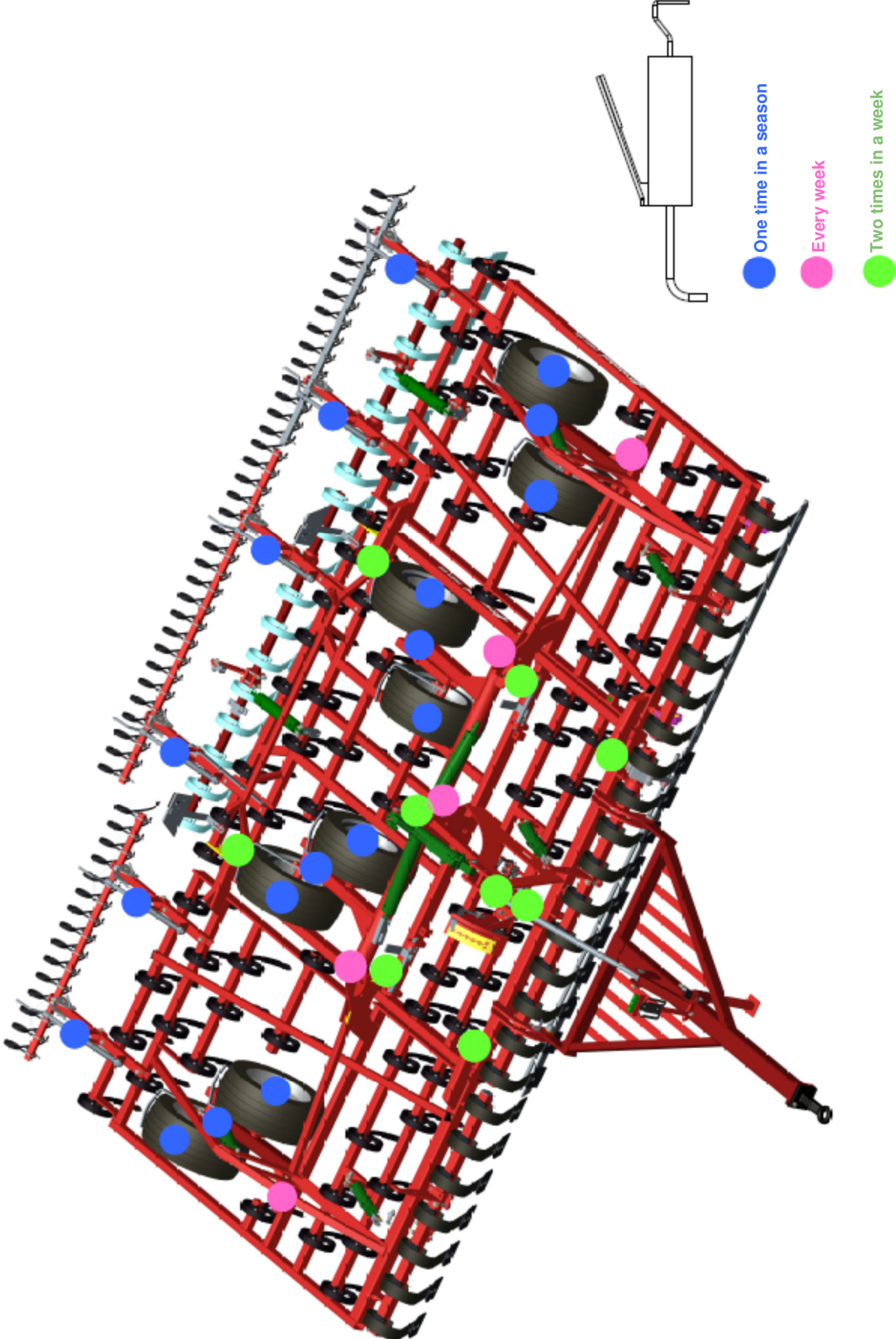

Tine

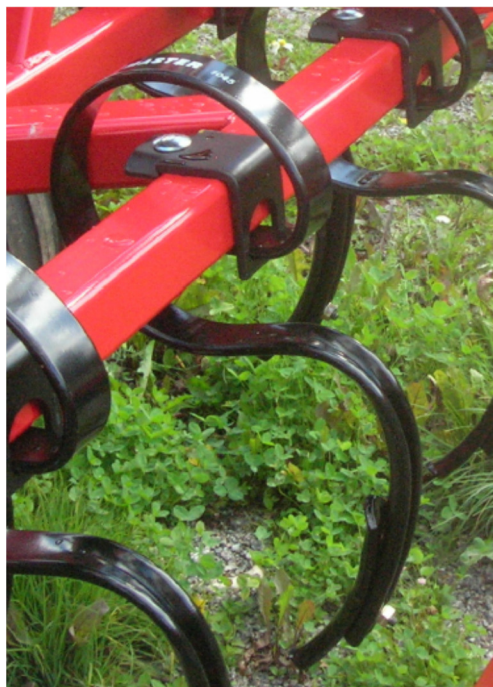

Replacing a tine

A tine must be replaced if it is broken. Open the tine mounting bolt and remove the old tine. Leave the bolt in the tine clamp and insert the new tine into the clamp. Pull the tine backwards so that the bolt contacts the tine axle. Tighten the nut to 110 Nm. Retighten the mounting bolt of the tine point after the first day of operation.

Replacing a tine point

Tine points can be reversed and attached with the old bolt and nut if this is done before the bolt head becomes excessively worn. Always replace the bolts and nuts when replacing the tine points with new ones.



Never hold the bolt head with your hands when turning the tine point nut.

Bogie beam

Checking the bogie beam bearing

- Check the clearance of the bogie beam bearing before lubrication.
- Extend the cultivator on a level surface.
- Lower the cultivator on its tines so that the wheels lift off the ground.
- Push the rear wheel so that the front wheel is off the ground. Move the bogie sideways. If you feel play in the bogie beam, tighten the bogie beam bearing according to the instructions.

Tightening the bogie beam bearing

- Extend the cultivator on a level surface.
- Lift the cultivator up on its wheels.
- Place secure jack stands under the frame beams at the rear end of the cultivator. Use 2 jack stands per section.
- Lower the cultivator so that it is supported by the jack stands and tow hook.
- Lift the wheels fully up.
- Open the lock washer tab and open the outer nut.
- Remove the outer nut and lock washer.
- Tighten the inner axial nut to **40 Nm**. Hit the bogie beam against the limiter 2–3 times. Tighten the axial nut again to **40 Nm**. Repeat this procedure until the axial nut cannot be tightened with a tightening torque of **40 Nm**.
- Install the lock washer and tighten the outer nut to **40 Nm**.
- Turn the outer nut in the closing direction to align a lock washer tab to the nearest locking groove.
- Lock the nut by turning the tab into the groove in the outer axial nut.
- Press petroleum jelly into the hub until some lubricant comes out of the hub.

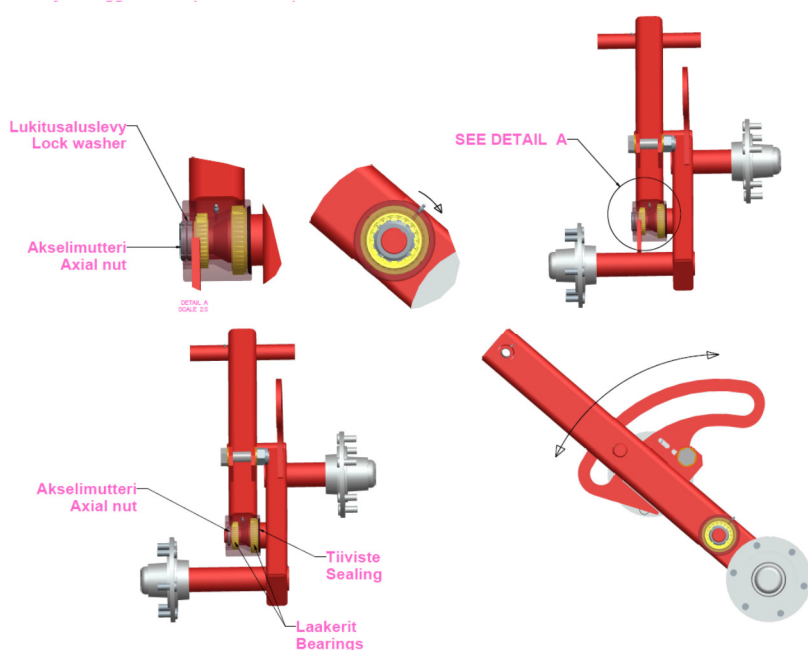

Wheel hub

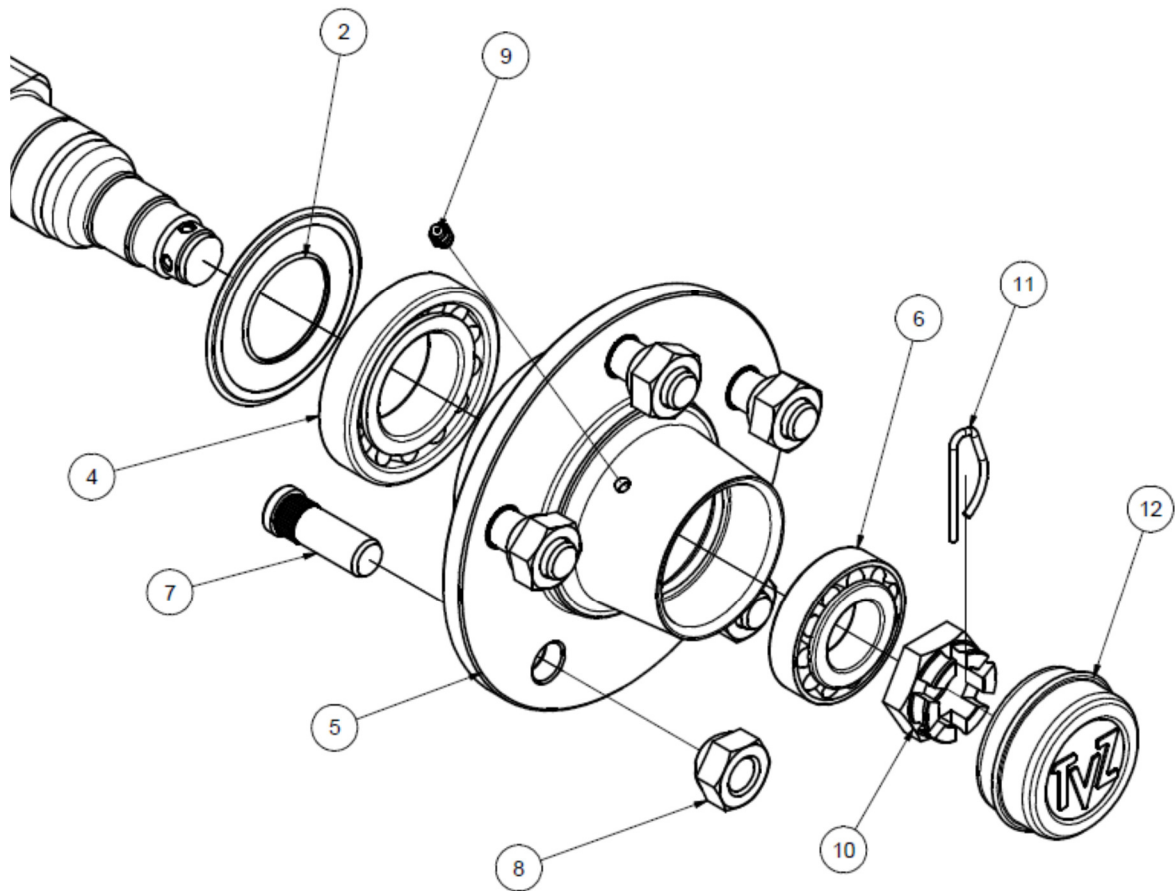

- Check the bearing clearance before lubricating the hubs.
- Extend the cultivator.
- Lower the cultivator on its tines so that the wheels lift off the ground.
- Hold the wheel firmly and feel for play: the wheel must rotate easily without perceptible play in the bearing.
- To tighten the bearing, remove the dust cap (12) by tapping. Remove the castle nut pin (11) and tighten the castle nut (10) while rotating the wheel until you feel light resistance in the bearing.
- Open the nut until the pin can be installed in the next slot in the nut.
- If a nut slot is already aligned with the pin hole, open the nut to align the hole with the next slot.
- Tap the dust cap in place.
- Press petroleum jelly into the hub until some lubricant comes out between the hub seal (2).
- Finally, check the tightness of the wheel nuts.

Hydraulics

Rear crossboard cylinders

Wing section lift cylinders

Depth control cylinders

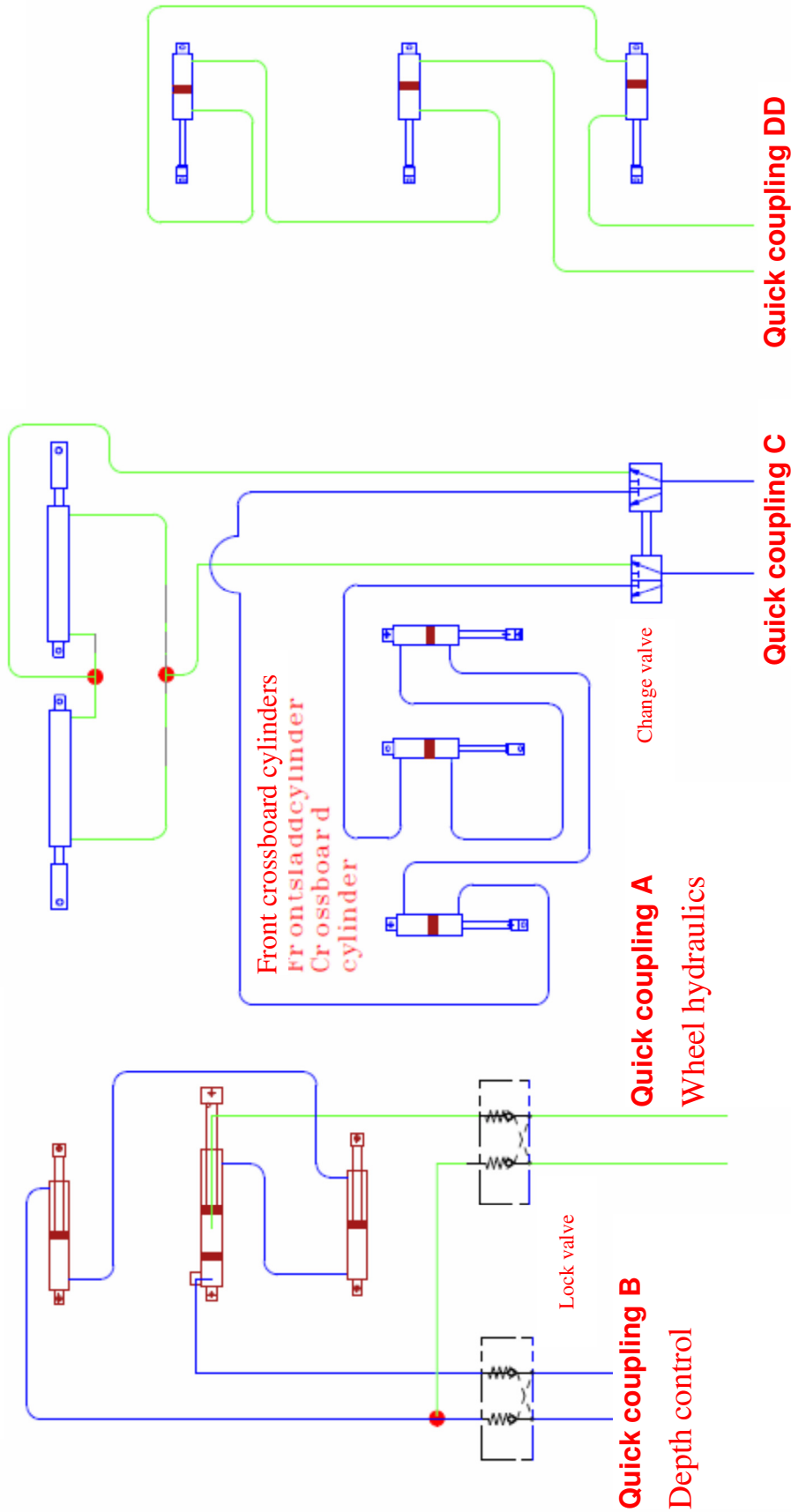

The working depth of MAGNUM PLUS seedbed cultivators is controlled **hydraulically**. The cylinders for front crossboard hydraulics and wheel transport hydraulics are connected in series, ensuring that all functions controlled by these cylinders take place accurately at the same rate.

Change valve



The change valve assemblies control the hydraulics for the front crossboard and wing sections. Their purpose is to distribute the pressure of the same hydraulic outlet to the front crossboard cylinders or wing section lift cylinders depending on the position of the cultivator (work or transport position).

It is advisable to lubricate the change valve shafts with oil before the season and before long-term storage.

Change valve control rod

- The total movement range of the change valve is about 90 degrees (45 degrees in both directions).
- To adjust the control rod, lift the cultivator on its wheels so that the turning lever assembly of the control valve is turned backwards.
- Open the lock nuts of the control rod ball joint.
- Detach the ball joint from the change valve turning lever and adjust (extend or retract) the control rod as necessary.
- Attach the ball joint to the turning lever and lower the cultivator on its tines.
- Now the turning lever assembly is turned forwards. Test the operation of the front crossboard.
- If the front crossboard operates correctly, secure the lock nuts of the control rod. Otherwise, perform the adjustment procedure again.

Disassembling the valve



- Open the bolts of the lever assembly and remove the levers.
- Open the body bolts.



- When disassembling the valve, pay attention to the markings in the valve stem!
- Mark the oil channel directions on the valve stem to the valve body with, for example, a marker pen.
- The marks must point to the same direction in both valves!



- Open the end nuts.
- Remove the plastic bushings.
- Mark the position of the ball before removing it from the housing!
- Remove the stem by pushing it into the valve housing.

6. WARRANTY

6. WARRANTY

We offer a one operating season warranty for POTILA MAGNUM PLUS seedbed cultivators.

Terms of warranty:

1. The manufacturer shall, free of charge, replace any parts that fail due to manufacturing defects or substandard materials during the warranty period. The warranty does not, however, cover consumable parts.
2. During the warranty period, the machine owner shall be obligated to pay for any warranty repair work and freight charges as well as travel and daily expenses for service technicians.
3. The warranty does not cover damages caused by improper use, insufficient maintenance, unauthorised alterations to the equipment, traffic accidents or other reasons beyond the scope of inspection. The warranty does not cover damages caused by using the machine with a clearly oversized tractor.
4. If any defect found during the warranty period is repaired by an outside party, the manufacturer shall compensate the owner for any repair costs incurred, provided that this type of arrangement was agreed upon in advance with the manufacturer representative.
5. The manufacturer shall not be held liable for any loss in revenue or other direct or indirect losses that the damaged machine may have incurred while out of service.

7. EC Declaration of Conformity

EC DECLARATION OF CONFORMITY

POTILA Tuotanto OY
Kiikostentie 7
FI-38360 KIIKOINEN
FINLAND

We thus assure that the following machines:

Potila Magnum Plus 700, 800, 900, 1000 and 11000 harrows starting from serial number **191** meet the machine structure requirements provided in machine directive 2006/42/EY.

Furthermore, the following harmonized standards were used in engineering the machine:

ISO 4254-1:2013

Loimaa 11th of January 2016



Vesa Mäkelä
Kotimäentie 1
FI-32210 Loimaa
Finland

The undersigned is also qualified to compile technical documentation for the machines mentioned above.

This document in Finnish is the original and shall prevail.